

| | | | | |
|--------------------|-----------------------|--------------------|-----------|-----------------------|
| TOTAL TRAVEL | 144 INCHES 3658 mm | No. OF LANDINGS: 2 | JOB No. - | SERIAL No. - S.O - |
| LOCATION | - | - | - | - |
| ARCHITECT | - | - | - | - |
| GENERAL CONTRACTOR | - | - | - | - |

TRUS-T-LIFT

DWN. BY: B.G.

CHECKED BY:

SCALE: N.T.S.

DATE: 20/02/2014

DRAWING No. 2/2

144URLDUGNCST-750

REV A

TRUS-T-LIFT ELEVATOR
INSTALLATION DETAILS
AND SPECIFICATIONS

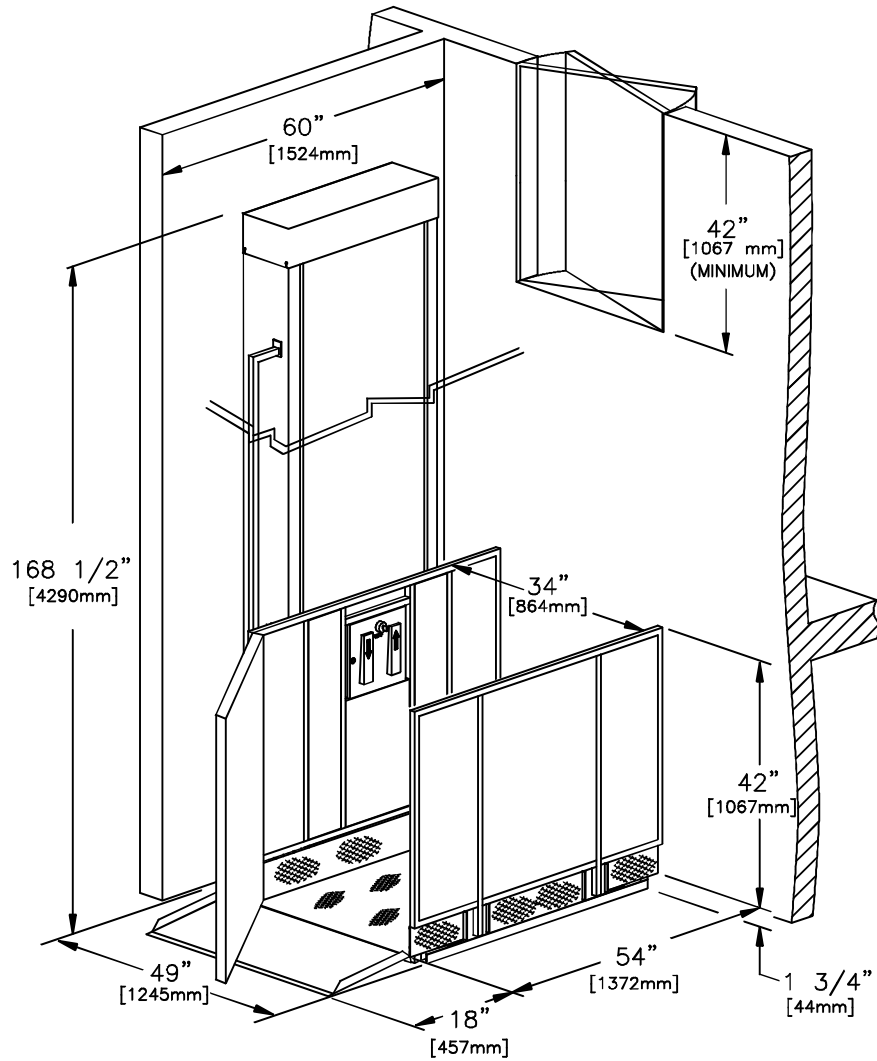

SPECIFICATIONS:

- 34" x 54" [864mm x 1372mm] LIFT PLATFORM
- 49" x 54" [1245mm x 1372mm] FOOTPRINT
- 168-1/2" [4280mm] TOWER HEIGHT
- 0" - 144" [0mm - 3658mm] LIFT RANGE
- MAXIMUM LOAD 750 lbs. [340 Kg.]
- 8 F.P.M [0.04 M/S] LIFT SPEED
- SCREW NUT SYNCHRONOUS BELT DRIVE
- MOTOR: 1/2 H.P. 110V A.C.
- POWER SUPPLY: 110V/1PH/60HZ C/W 15A FUSED DISCON.
- NON-LOAD BEARING BACKUP SAFETY NUT ON LIFT SHAFT
- ZERO-LOAD START IN BOTTOM POSITION
- SAFETY HANDRAIL ON CARRIAGE

*DESIGNED & BUILT TO MEET ANSI-A18.1-2008 Safety Code

*DOORS: - UPPER LANDING GATE C/W ELECTRICAL MECHANICAL INTERLOCK

| |
|---|
| <input type="checkbox"/> Accepted as Shown |
| <input type="checkbox"/> Revise and Resubmit |
| <input type="checkbox"/> Accepted as Modified |
| Date: _____ |
| Per: _____ |

TRUS-T-LIFT DIMENSIONS

NOTES:
- Dimensions are in inches & [mm]

| | | | | | | | | | | | | | |
|--------------------|-----------------------|--------------|--------------------|-----------|-----------------------|---|---------------------|--------------------------------------|----------|-----------------|--|--|--|
| TOTAL TRAVEL | 144 INCHES 3658 mm | INCHES mm | No. OF LANDINGS: 2 | JOB No. - | SERIAL No. - S.O - |  | | | | | | | |
| LOCATION | - | - | - | - | - | | | | | DWN. BY: B.G | TRUS-T-LIFT ELEVATOR INSTALLATION DETAILS AND SPECIFICATIONS | | |
| ARCHITECT | - | - | - | - | - | | | | | CHECKED BY: | | | |
| GENERAL CONTRACTOR | - | - | - | - | - | SCALE: N.T.S. | DATE: 20/02/2014 | DRAWING No. 1/2 144URLDUGNCST-750 | REV A | | | | |