



Commercial & Residential Elevators

**RAM Manufacturing Ltd.**

10203 184 St. Edmonton, AB Canada T5S 2J4

**1-800-563-4382**

Fax 1-780-486-2920

www.trustram.com



Commercial & Residential Vertical Platform Lifts

# TRUS-T-LIFT™ 750

## Back Up Safety Nut Indicator Bracket

### PRODUCT BULLETIN

The following Bulletin is to inform all relevant Trus-T-Lift™ 750 owners and dealer partners of an important safety consideration regarding Trus-T-Lift™ 750 units.

RAM has designed the ACME screw drive mechanism to comply with CSA B355 and ASME A18.1 code requirements that state a “double nut” arrangement is a suitable and safe design. The Trus-T-Lift™ 750 Back-Up Safety nut is identical in materials and design to the main drive nut and rides 1/2”-3/4” below the main drive nut. The Back-Up nut will only experience load should the main drive nut fail. When this happens the red bracket that moves with the Back-Up Safety nut will activate the lower limit switch allowing the lift to only travel once to the top landing preventing the lift from operating until repairs are made.

After some field reports that the lower limit switch rod had the possibility of not being engaged properly in the bracket. RAM has made a revision to the bracket to improve the capture method and ensure that the bracket face is closer to the limit switch.

This revision was put in to place as of July 15<sup>th</sup>, 2014 and this notice will only be relevant to any Trus-T-Lift™ 750 that was purchased between the period of May 1, 2013 and July 15<sup>th</sup>, 2014.

RAM is advising any owner or dealer of our products to:

1. Inspect their affected lift(s) to make sure the lower limit switch rod is captured properly.
2. Replace any older revision bracket with a new one during the required annual maintenance or when they observe that the rod is out of place.

RAM will provide a newly revised back up safety nut bracket free of charge to anyone who needs to replace the older version on a Trus-T-Lift™ 750. Please contact RAM technical support at 1-800-563-4382 to arrange for a new bracket should you need one.

Not replacing this bracket may result in, but not be limited to, the following consequences:

1. The inability of the control system to indicate when the primary drive nut has failed and requires replacement.
2. Failure to shut off the lift at the lower stopping point, which in turn may cause the drive screw to be displaced upwards damaging the belt retention block and having the belt slip off the main drive pulley.

The following image, figure 1, shows the old revision of bracket (item 44). If the lower limit switch rod is not captured in the slot as shown in the lower limit switch detail please replace it in the slot immediately and then proceed to procure and replace with a revised bracket. An image of the revised bracket is shown in figure 2 below.

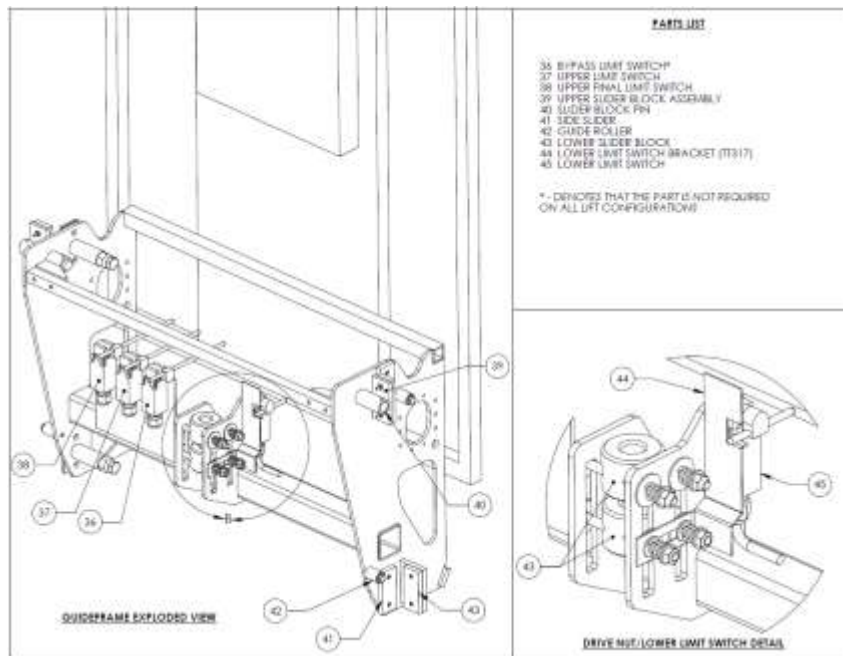

Figure 1: Trus-T-Lift™ Guide Frame Assembly



Commercial & Residential Elevators

# RAM Manufacturing Ltd.

10203 184 St. Edmonton, AB Canada T5S 2J4

1-800-563-4382

Fax 1-780-486-2920

www.trustram.com



Commercial & Residential Vertical Platform Lifts

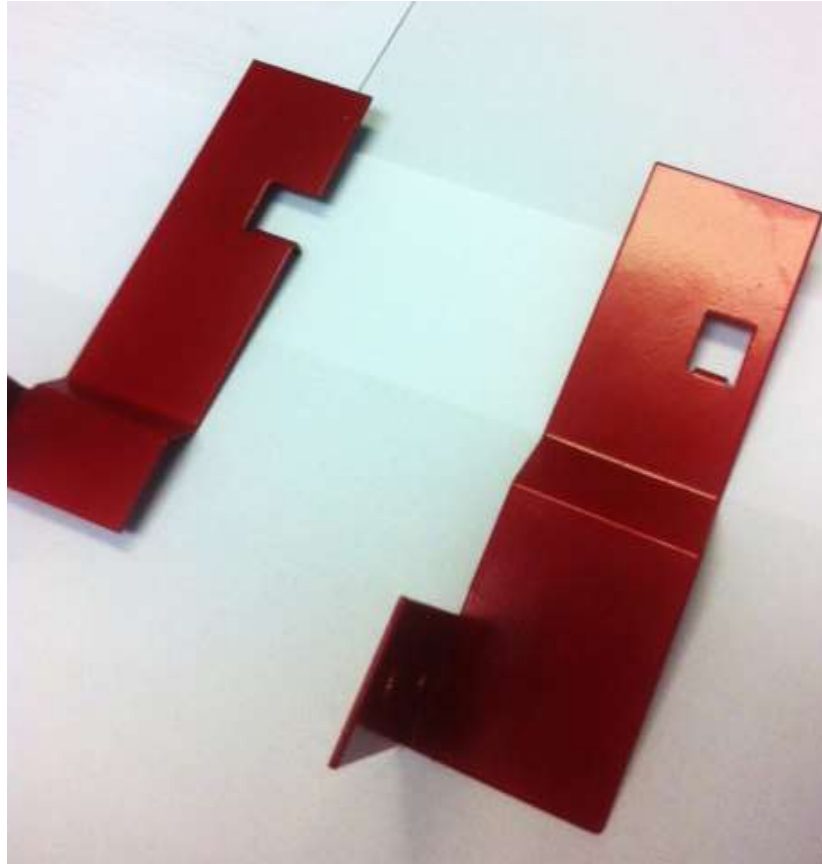

Figure 2: Old Revision Bracket on Left, Revised Bracket on Right