

Trus-T-Lift™ 750

Owners Operation Manual

Copyright 2016



Revision A – Aug 15, 2016

Section 1: Contents

Section 1: Introduction 2

Section 2: Safety and Warnings 2

Section 3: Operating Instructions 3

Section 4: Emergency Stop Switch and Key Switches..... 3

Section 5: Top Drive Manual Crank Operation 4

Section 6: 90 Deg Manual Crank Access 5

Section 7: Maintenance 7

Section 8: Basic Trouble Shooting 7

 8.1 Replacing a Fuse 7

 8.2 No Power to the lift. Lift will Not Operate 7

 8.3 Lift Runs Up and Not Down **Error! Bookmark not defined.**

 8.4 Lift Runs Up and Down but Doors or Gates will Not Unlock..... **Error! Bookmark not defined.**

Section 1: Introduction

Thank you for selecting the Trus-T-Lift™. When operated properly the Trus-T-Lift™ is designed to provide years of trouble free service with proper maintenance. This manual is provided to show you how to operate the lift safely. Please read this manual thoroughly before operating your lift for the first time. We recommend your lift be installed and serviced by a qualified technician. If you are having problems with the lift please contact your RAM dealer or call our technical support line at 1-800-563-4382.

Section 2: Safety and Warnings

Warning

Read all instructions thoroughly before installation or use of this lift. Failure to following the instructions in this manual and the associated manuals for testing and operation could result in serious injury or death. In addition, it will render RAM's warranty null and void.

Do not override any of the safety devices provided with the lift. Doing so will likely lead to serious injury or even death.

Ensure there is a minimum of 2in (50mm) and a maximum of 3in (75mm) clearance between any part or edge of the carriage that could possibly be used as a supporting handhold and any part of the fixed installation to prevent the trapping of a hand during the travel of the carriage. See RAM installation drawings for details.

The lift is intended for use by people and not to be used for cargo or other purposes. Lifting capacity is up to a maximum of 750 lb. unless otherwise noted on the lift and in RAM's supplied documentation. **(DO NOT OVERLOAD THE LIFT)**. Overloading the lift will render RAM's warranty null and void.

Ensure that there is nothing obstructing the carriage travel before operating the lift.

RAM Manufacturing Ltd. (RAM) disclaims any and all liability for any personal injury or property damage resulting from the operation of a product that has been modified from the original design. No person or company is authorized to change the design of the product without written authorization by RAM

Failure to observe and complete the required maintenance for your lift product will render the warranty null and void and may present significant risk that could lead to injury or death.

The list of warnings may not be exhaustive, due care around equipment should be observed.

If uncertain, please contact the manufacture or a qualified installer.

For product updates and bulletins, please refer to our website

www.trustram.com

Section 3: Operating Instructions

To raise or lower the carriage press either the UP or DOWN paddle (See Figure 1) and maintain continuous pressure on the paddle until the lift stops automatically at the landing.

If you decide to change the direction of travel of the lift before it reaches the landing, you must release the paddle and wait for the lift to come to a COMPLETE STOP before pressing the other paddle.

If you need to stop the lift before it reaches the landing, simply release the UP or DOWN paddle and the carriage will stop immediately.

Section 4: Emergency Stop Switch and Key Switches

You can also stop the lift by pressing the red STOP button (See Figure 1 below). To release, simply pull out the button.

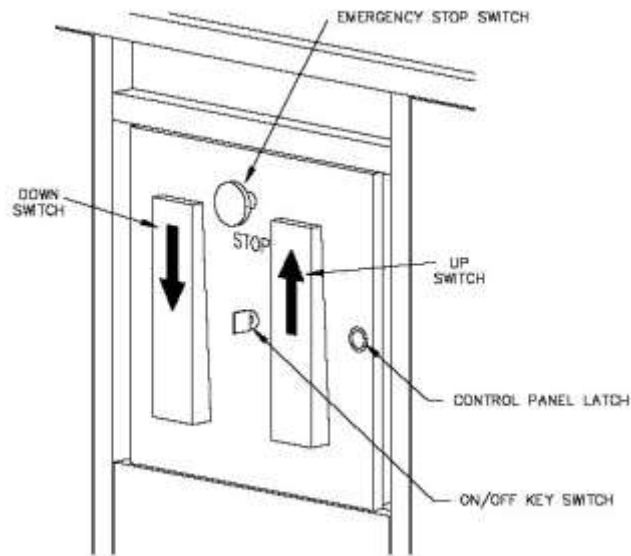

Figure 1: Main control Panel

Section 5: Top Drive Manual Crank Operation

If a power outage occurs while the lift is in use and a passenger is stranded between landings, the carriage can be manually raised or lowered using the Hand Crank Tool provided and using the following procedure:

- Unplug the power cord
- Insert the square end of the Hand Crank Tool through the access hole at the upper right side of the tower (See Figure 2).
- Turn the Hand Crank Tool clockwise to lower the lift and counter-clockwise to raise the lift.

Warning

If you are unable, or choose not to, use the manual crank to assist in lowering the platform to assist someone in egress from the lift please note that there may be significant risk of injuring yourself and/ or the passenger and RAM would recommend contacting local emergency services to support your efforts and avoid injury.

Section 6: 90 Deg Manual Crank Access

In some cases, a 90 deg manual crank option will be configured as part of your lift. When operating 90 deg removing the top cover is not required to perform the function.

Before running or maintaining manual crank, always unplug power cord to disconnect power supply.

- In order to perform the manual operation, you will need a ratchet wrench with 3/8" square drive extension. One of these will have been provided with the lift when originally shipped. This is item 3 in the drawing TI001.
- Insert the 3/8in ratchet with the extension (if accessing through a wall) and engage it with the receptacle at the end of the main drive shaft as shown in image below.
- Push and hold the whole device to stay in the engaged position while rotating the ratchet in the desired direction.

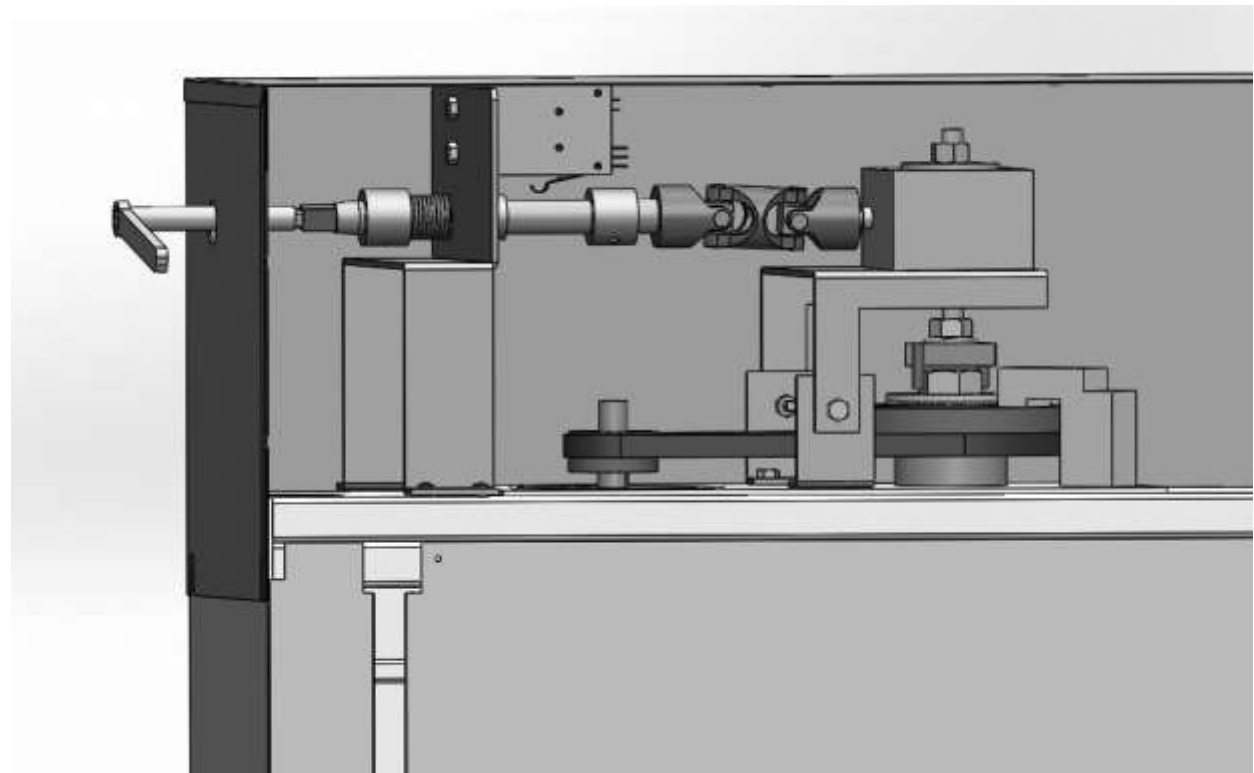

Push to engage Manual crank

- After the lift platform reaches the desired landing or level, reverse input shaft approximately 5 rotations to relieve the load on the gearbox and drive interface and then allow the biasing spring to return the manual crank to disengaged position (as shown in figure 11-4).

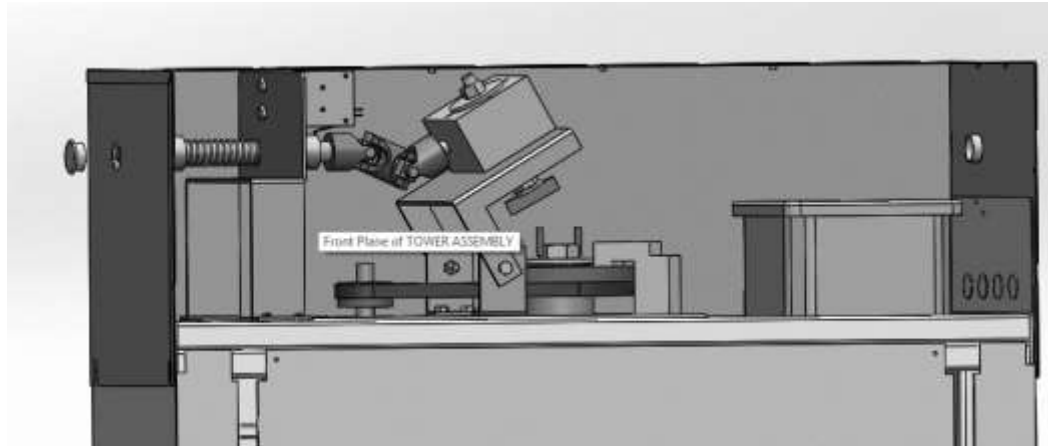

Manual crank returns to disengaged position

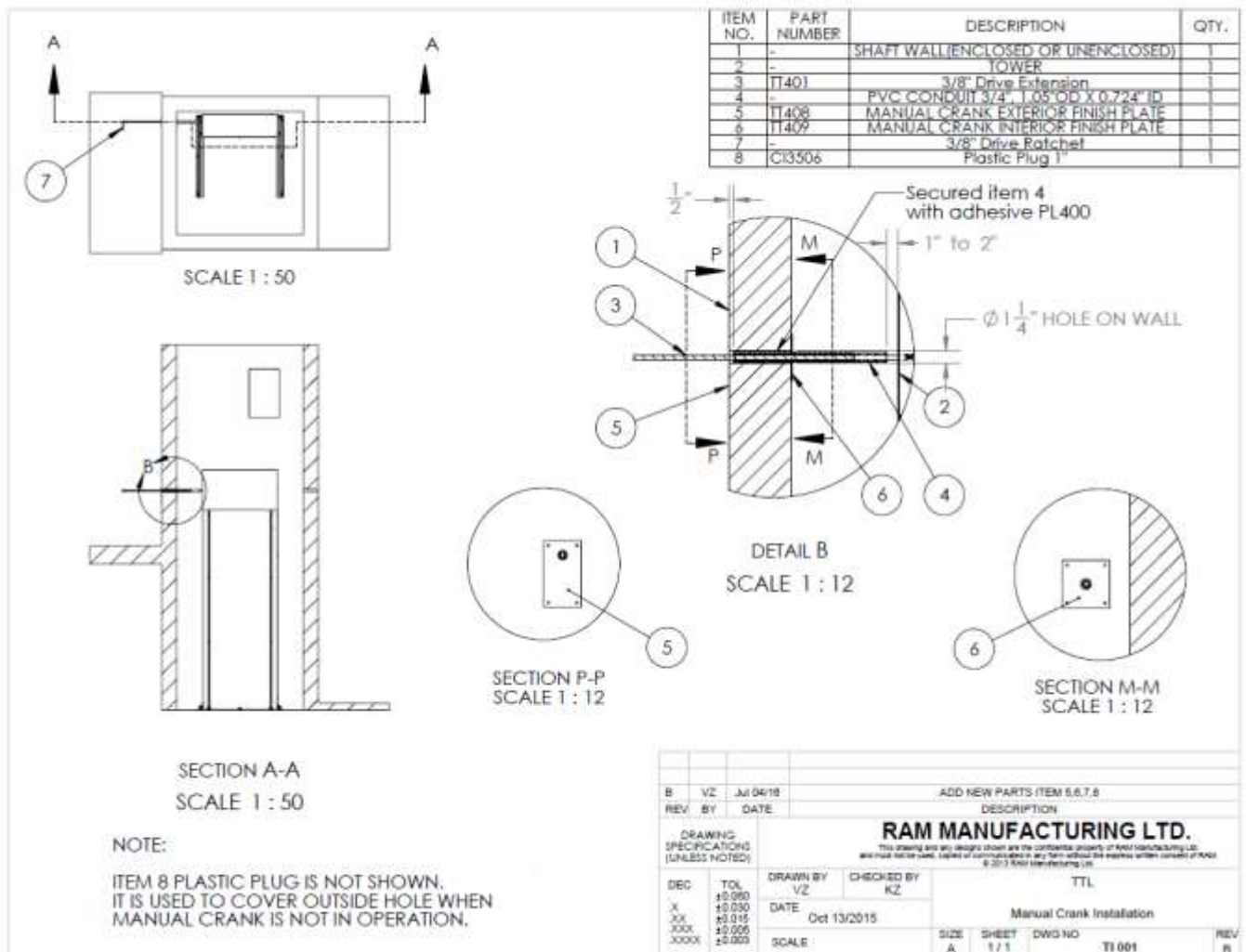

Section 7: Maintenance

Minimum maintenance requirements and a number of common procedures are outlined in the maintenance manual that accompanied your equipment and that manual should be retained by the owner of the lift to allow them to keep track of maintenance and service as well as have a reference of the minimum requirements.

If you do not have a copy of the maintenance manual please contact RAM to obtain one.

Warning

Failure to observe and complete the required maintenance for your lift product will render the warranty null and void and may present significant risk that could lead to injury or death.

Section 8: Basic Trouble Shooting

8.1 Replacing a Fuse

Unplug the power cord.
Open the control box with the key provided.

The fuses are located in the control box on the right hand side. Replace the blown fuse with a fuse with the same Amp rating.

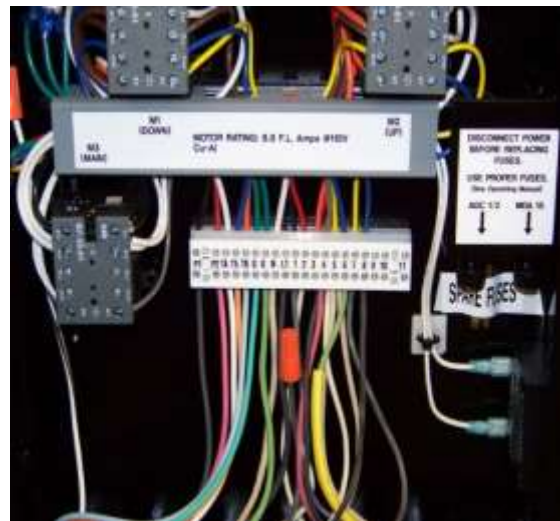

8.2 No Power to the lift. Lift will Not Operate

Check to see if the lift has been plugged in or the power supply has been hooked up. Check if emergency button is depressed. Pull to “on” position. Ensure that the power key on the control panel is in the “on” position. If you have interlocks ensure they are in the “locked” position. Check that the Top cover Switch (if it is included) is properly depressed by removing the top cover and inspecting the switch.

8.3 Lift Runs Up and Not Down

Ensure that the Lower Limit Switch Rod is resting inside the Red Safety Bracket.
Check that the Safety Pan has not been activated.

Safety Pan must be Free Floating.

Additionally, the safety pan must be connected at the “inside junction box underneath the main control panel and behind the control wall.

8.4 The lift won't raise the full capacity load

Verify the current being drawn by the unit by using a clamp-on current meter or multimeter. It should be less than 13Amps at full load.

Check the adjustment on the sliders – ask RAM for procedure if you do not know how to do this.

Clean the drive screw and guide rails thoroughly. Reapply RAM approved grease Mobilith SHC 460PM to the drive screw and work it in by raising and lower the platform with reduced load. If this improves the lifting capacity but it still does not lift full load clean and re-apply again as other grease may have been used and was not fully removed.

8.5 Lift Runs Up and Down but Doors or Gates will Not Unlock

Check to see that interlocks are properly mounted, and latches properly mate with the interlock. For Commercial lifts the UPS must be turned on or the doors will not open.

Contact Your RAM Dealer Partner or a local Elevating Device Professional for more challenging issues.

Please have your serial number ready if you call RAM directly so we can determine what lift you have.

Serial Number is located inside of the control panel door.