

Trus-T-Lift™ 750

Limited Maintenance Manual

Copyright 2016



Revision B – Oct 3, 2016

Section 1: Introduction

Thank you for selecting the Trus-T-Lift™. When operated properly and with proper maintenance the Trus-T-Lift™ is designed to provide years of trouble free service. This manual is provided to outline the minimum maintenance requirements for a Trus-T-Lift™ but your specific product may require additional maintenance depending on usage and environmental conditions.

Please read this manual in combination with the corresponding electrical and installation drawings.

If you are having problems with the lift, please contact your RAM dealer or call our technical support line at 1-800-563-4382.

Section 2: Safety and Warnings

Warning

Read all instructions thoroughly before installation or use of this lift. Failure to following the instructions in this manual and the associated manuals for testing and operation could result in serious injury or death. In addition, it will render RAM's warranty null and void.

Read all instructions thoroughly before installation or use of this lift. Failure to following the instructions in this manual and the associated manuals for testing and operation could result in serious injury or death. In addition, it will render RAM's warranty null and void.

The lift is intended for use by people and not to be used for cargo or other purposes. Lifting capacity is up to a maximum of 750 lb. unless otherwise noted on the lift and in RAM's supplied documentation. **(DO NOT OVERLOAD THE LIFT)**. Overloading the lift will render RAM's warranty null and void.

RAM Manufacturing Ltd. (RAM) disclaims any and all liability for any personal injury or property damage resulting from the operation of a product that has been modified from the original design. No person or company is authorized to change the design of the product without written authorization by RAM

Do not override any of the safety devices provided with the lift. Doing so will likely lead to serious injury or even death.

Ensure there is a minimum of 2in (50mm) and a maximum of 3in (75mm) clearance between any part or edge of the carriage that could possibly be used as a supporting handhold and any part of the fixed installation to prevent the trapping of a hand during the travel of the carriage. See RAM installation drawings for details.

Ensure that there is nothing obstructing the carriage travel before operating the lift.

Failure to observe and complete the required maintenance for your lift product will render the warranty null and void and may present significant risk that could lead to injury or death.

Do not work underneath the platform without fist securing the platform and/or using a shoring bar as well as locking out the controls

Section 3: Maintenance Requirements

3.1 Monthly Inspection (by owner or technician):

3.1.1 Inspect all gates/doors and ensure they are locked when the lift is not at the landing. Also check that the lift will not run unless the gates / doors are fully closed and locked once the platform is more than 2" (50mm) from the landing.

3.1.2 Inspect under pan safety device for correct operation

3.1.3 Verify E-Stop button is working

3.1.4 Inspect the toe plate and ensure it is operating smoothly and moving into the up position when the lift leaves the lower landing. Also test that it will resist load being applied to it (up to 125lb)

3.2 Annual Maintenance (by technician):

The Trus -T-Lift™ should be inspected and maintained annually. The following is a non-exhaustive list items of that should be checked as part of an annual maintenance in order to maintain safe operation of your lift. An inspection and maintenance is required to be completed by an authorized RAM dealer for any extended warranty claims to be valid.

All the above monthly items + the following:

3.2.1 Inspect the drive nuts

Compare the amount of movement in the drive nuts from side to side and up and down without rotating the drive nut at all. If they feel overly sloppy or as though threads may be missing, then they need to be replaced. Signs of bronze thread material or shavings are another indicator of worn lifting nuts. If the amount of movement is minimal spin the drive nuts by hand to check for resistance, if any resistance is felt or the drive nut binds then they must be replaced.

3.2.2 Inspect the drive screw

Inspect the drive screw for any irregularities, sharp edges or foreign objects and dirt caught in the threads. Be sure no damage exists to the drive screw and that it is entirely clean of debris. Replace screw if damaged.

3.2.3 Clean and re-lubricate the drive screw

In order to lubricate the drive screw you must remove the main front panel and a carriage guide frame panel. Use a clean rag to wipe all of the grease off of the screw. Liberally apply Mobilith SHC-460PM grease on the drive screw.

3.2.4 Inspect the drive belt

Remove the top cover and inspect the drive belt for wear. A small amount of black rubber bits below the belt is normal. If there is any significant sign of wear to the belt, replace.

3.2.5 Inspect for surface damage and complete touch ups to coatings

Wear and tear may occur on powder coated steel surfaces resulting in scratches. Small points of damage can be wire brushed and touched up with the small touch up paint containers that come with each lift RAM ships out. This will extend the life and cosmetic look of you lift and is particularly important in any environments that are coastal or potentially corrosive.

3.2.6 Inspect cables

Tears in insulation should be patched where possible and if bare wire is present new replacement cables should be purchased and installed by a qualified technician. Consult your RAM dealer for spare parts should they be required.

3.2.7 Inspect for correct functioning of toe plate – if applicable

The toe plate actuation mechanism may be critical to access and both the mechanism and the toe plate itself should be examined. If there are any concerns adjust the mechanism or repair/ replace it.

3.2.8 Re-check platform alignment and clearances

Buildings and construction “settles” over time and adjustments may be required to ensure good clearances and alignment of the lift. Consult the appropriate sections of the installation manual or RAM’s technical support team for guidance.

3.2.9 Inspect and Test All Interlocks and Safety Devices

Interlocks and all other safety devices should be tested to ensure they work in the appropriate manner. If you are uncertain whether they are operating correctly, please consult with your RAM dealer or call RAM's technical support team.

3.2.10 Complete testing outlined in section 4

Section 4: Testing Required

Once all the wiring connections are confirmed, the mechanical assembly is complete and the lift is secured you can proceed with testing to prove that all systems and main safety functions are active and functional.

4.1 Weight Testing

Every lift should be weight tested once the installation for mechanical and electrical items is complete to ensure that the lift is operating correctly. All lifts are tested at the factory but they are then disassembled and shipped to sites across North America.

The lift capacity may vary but this will be noted on the lift serial number label as well as other documentation.

Weight testing may comprise 2 elements:

1. Maximum Lifting capacity – you apply full load to the lift in the center of the center of the platform and the lift should operate in the upward direction. Current draw by the machine should be less than 13A.
2. Overload testing – North American Safety code requires that with 125% the lift does not move in the downward direction unintentionally. To test this, raise the lift roughly 12 in and apply 125% of rated working load and check that the lift does not move in the downward direction unintentionally. The lift is not required to lift 125% of working load.

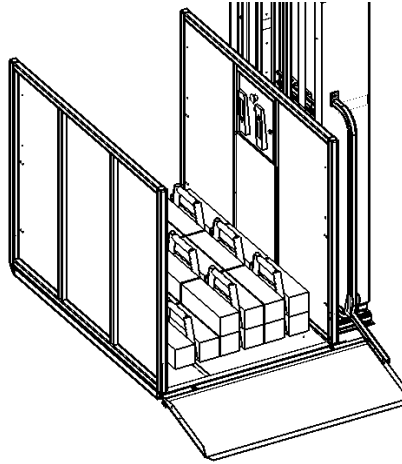

4.2 Check Upper Limit and Upper Final Limit Switch

Each lift is equipped with an upper limit switch that indicates to the control circuitry when the lift has reached the upper landing. This will be set as part of the installation process but you should physically and visually verify that the limit switch engages with the limit switch plate and that the limit switch rod is adjusted for full engagement.

Because the lift is setup to stop on the upper limit switch you will need to manually test if activating the upper final limit switch causes the lift to come to a stop before it reached the upper limit. This is a simple process of pressing the up control paddle and then as you move up depress the upper final limit switch. If the lift does not come to a stop, there is something wrong and you will need to go through a trouble shooting exercise.

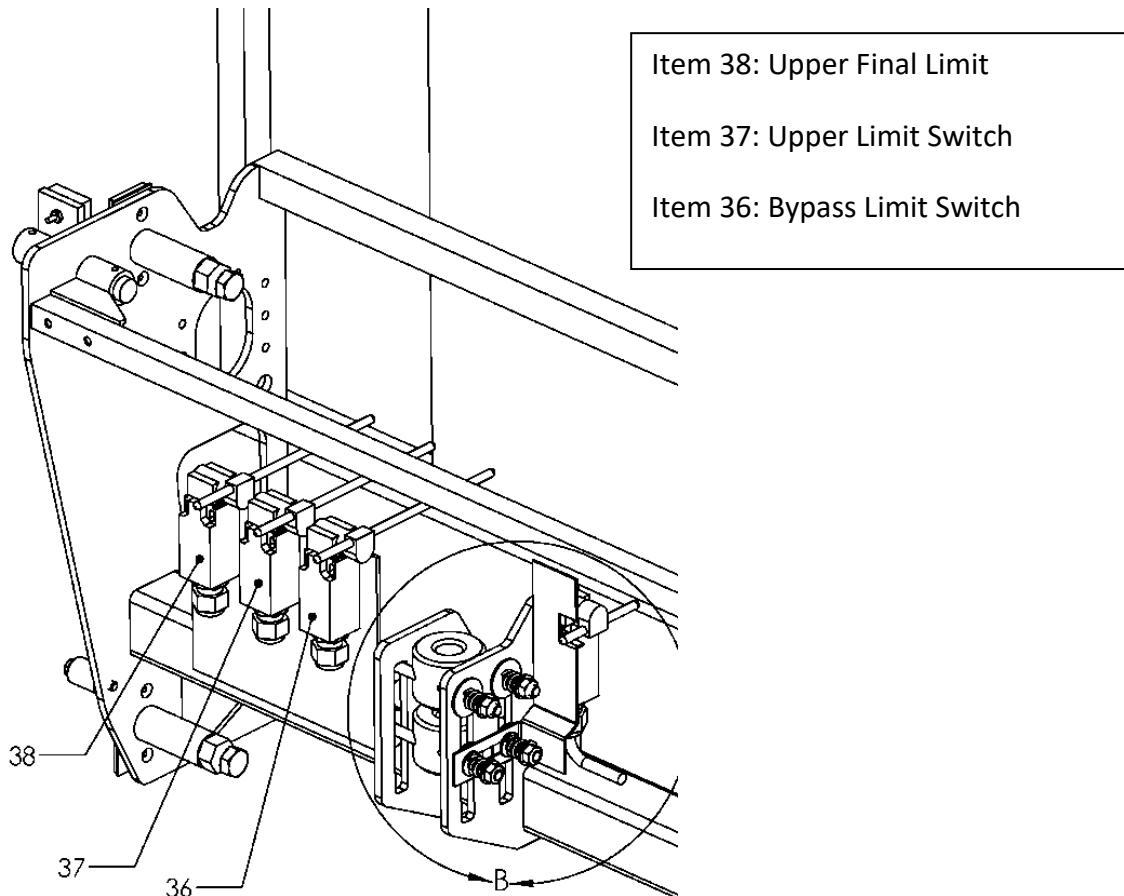

4.3 Verify Bypass Switch Operation

If your lift comes equipped with a BYPASS switch you will need to verify that it operates correctly. The BYPASS switch is used to allow the lift to operate within 50mm of the upper landing while the interlock is electrically unlocked. To test the bypass switch, move platform to the top landing and the upper landing gate/ interlock should unlock. Leave the gate/ lock in the open position and then run the lift down while monitoring the bypass switch visually. The lift should stop roughly 2in (50mm) down from the top landing when the by pass switch disengages from the limit switch plate. If this is not the

case there is something wrong with the switch or wiring and a trouble shooting exercise should be undertaken.

Lastly, check that the rod engages fully with the limit switch plate.

4.4

4.5 Check Drive Nut Switch

Verify that as the platform/ mechanical stops come in to contact with the foundation the limit switch is engaged with the red safety bracket and that this cuts power to the motor.

Also verify that the drive screw stops spinning prior to the drive nut bolts hitting the end of the slots in the guide frame.

If the drive nut bolts hit the end of the slots before the screw starts spinning the drive screw will be pushed up and the bearing on which it rests at the top of the lift will come out of the bearing raceway; this can cause damage to the bearing and may cause the belt to come off of the main drive pulley in extreme cases.

4.6 Verify Door and Gate Interlocks

Depending on the number of landings you have each door interlock should be checked so that if the platform is not at the landing location the door or gate will not open.

Additionally, for each door or gate you should manually override to keep each one open in turn and verify that the lift will not operate.

4.7 Verify E-Stop Button Function

Verify that when the E-stop button is pressed then the lift will not operate.

For commercial lifts the alarm bell should also sound.

4.8 Verify Toe Plate Ramp Operation

If your lift has a toe plate ramp you should verify that the ramp deploys properly and makes full contact with the lower landing. The action should be smooth and consistent without binding or jerking of the motion. When the toeplate ramp is in the up position both the ramp and the linkage mechanism should resist up to 125lb of force without deforming.

Warning

For power wheelchairs that can exert loads higher than 125lb of force a toe plate is insufficient safety protection and a carriage gate option will also be required. See RAM product bulletin.

4.9 Verify that disconnects function correctly

Verify that when the disconnects are flipped power to the lift is cut off and, if this is a commercial lift, the interlocks at each landing (when the lift is in the correct position will open) and that the alarm and light on board the carriage are active.

4.10 Verify that key switches at each location function correctly

Verify that when a key switch at each landing or on board the lift is turned to the off position the corresponding buttons and control paddles do not operate the lift.

4.11 Additional Redundancy Tests for Commercial Applications

For commercial lifts there are often additional redundancy tests required to be completed during inspection. To prepare for an inspection where these are required RAM suggests doing the tests prior to the inspection so that the functions are confirmed.

RAM will typically include a copy of these redundancy procedures in a commercial lift package but if you do not have them please contact RAM and we will supply a copy.

Section 5: Maintenance Log:

Please keep a record of all maintenance done on the lift in the maintenance log provided in Appendix C.

**For product updates and bulletins, please refer to our website
www.trustram.com**

**Contact Your RAM Dealer Partner or a local Elevating Device
Professional for more challenging issues.**

**Please have your serial number ready if you call RAM directly so we
can determine what lift you have.**

Serial Number is located inside of the control panel door.

